

Y = altezza di caduta libera

X = dimensione minima area d'impatto

a = are di attenuazione d'impatto

b = superficie necessaria in caso di attrezzature con movimento forzato (altalene, scivoli, funivie, giostre)

PLAYGROUND

ESTENSIONE SPAZIO DI CADUTA

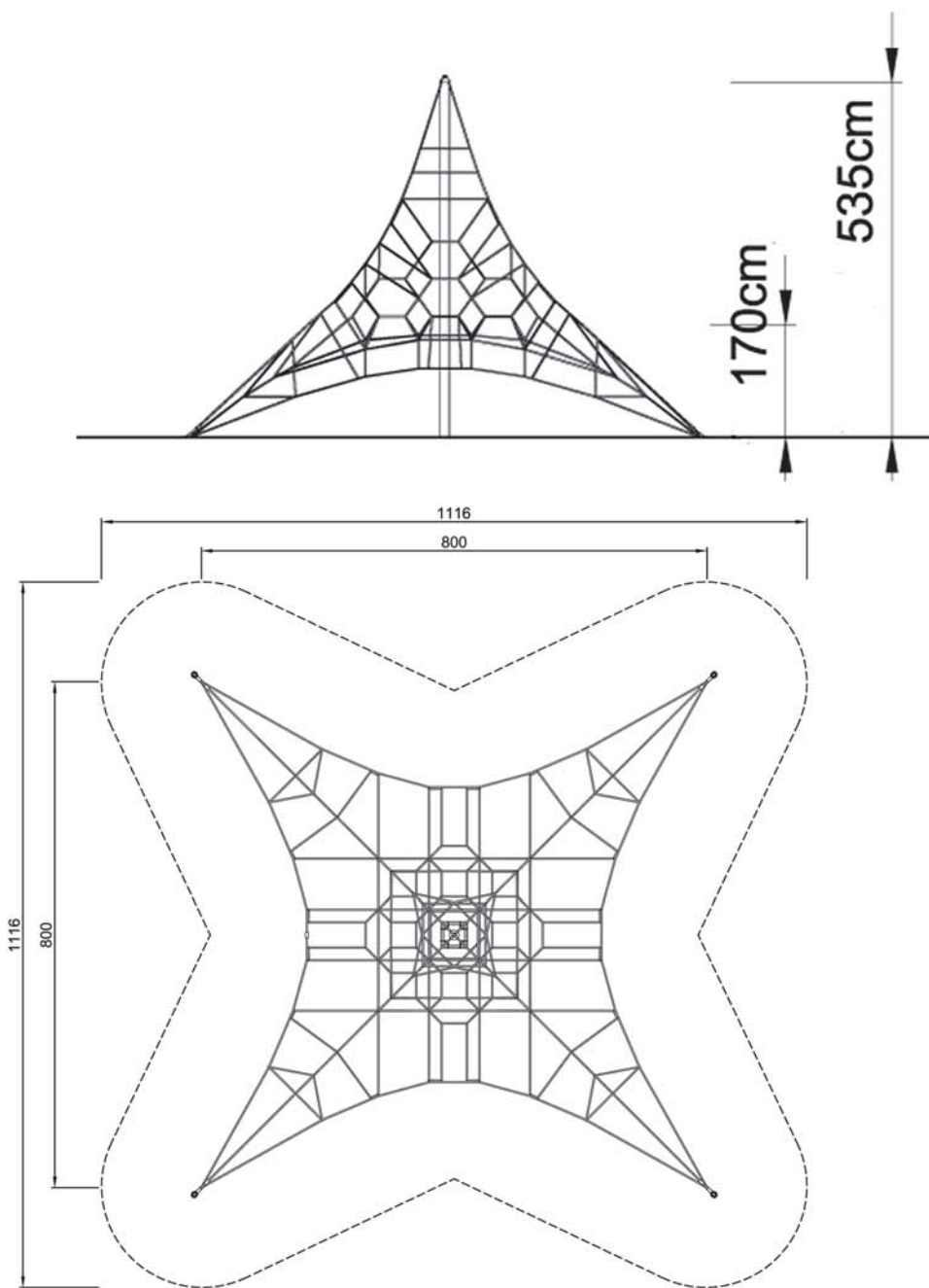

PIRAMIDE IN CORDA PER ARRRAMPICATA

ESEMPIO

(da scheda tecnica Kompan)

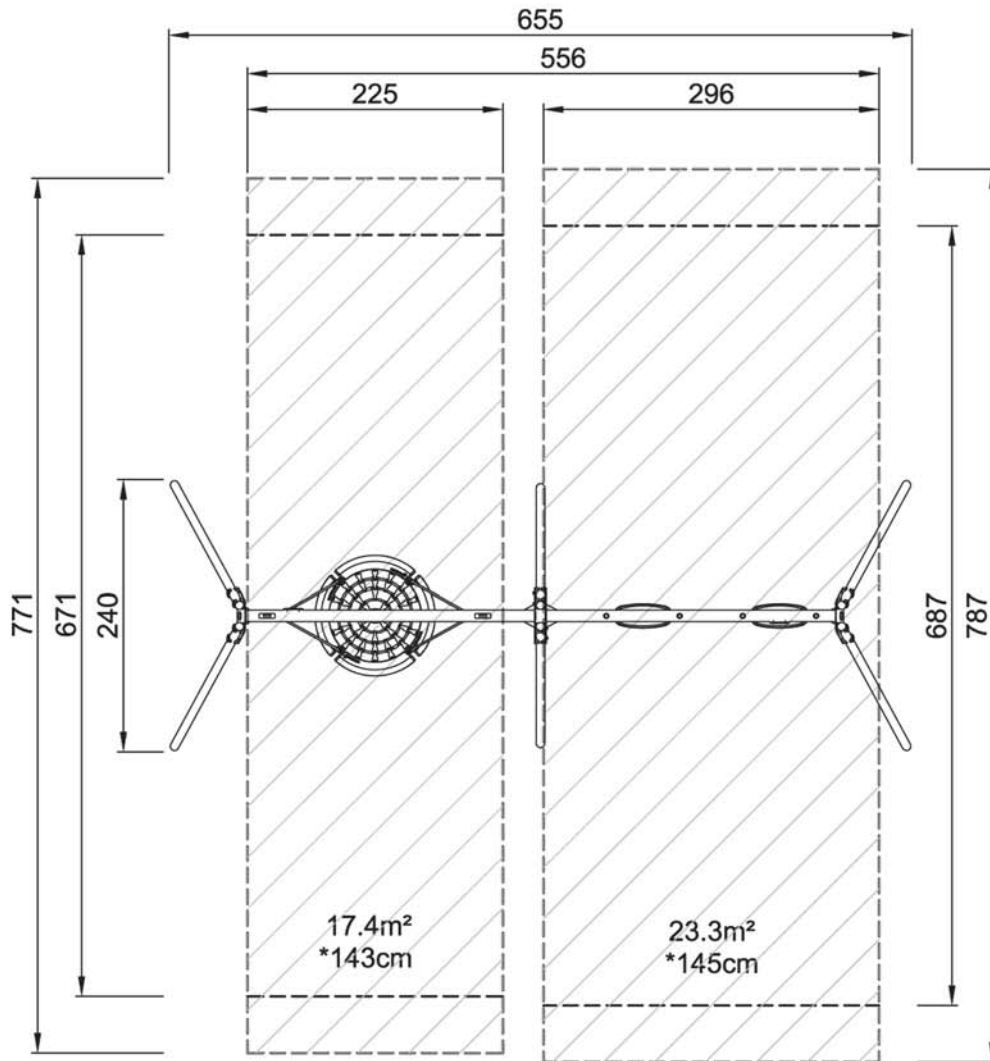
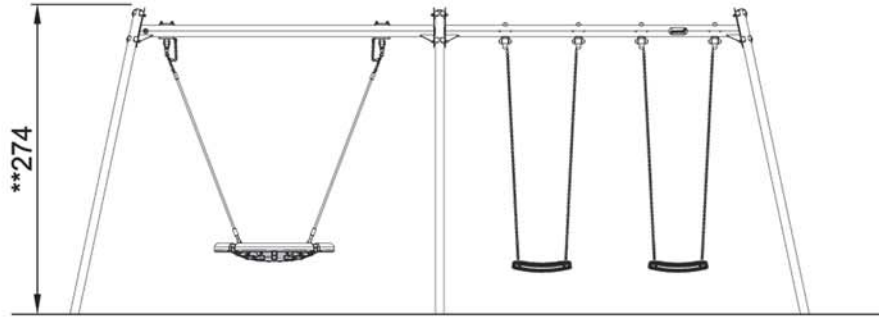

ALTALENA TRIPLA

ESEMPIO

(da scheda tecnica Kompan)

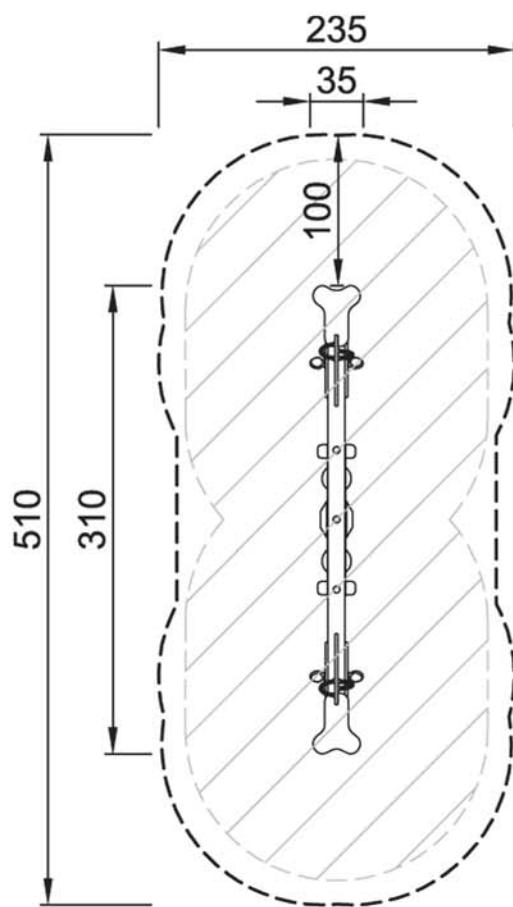
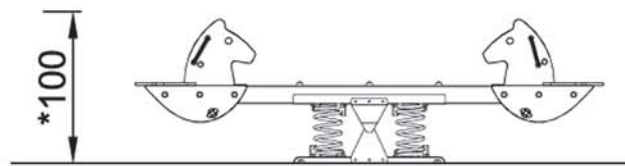

DONDOLO A MOLLA

ESEMPIO

(da scheda tecnica Kompan)

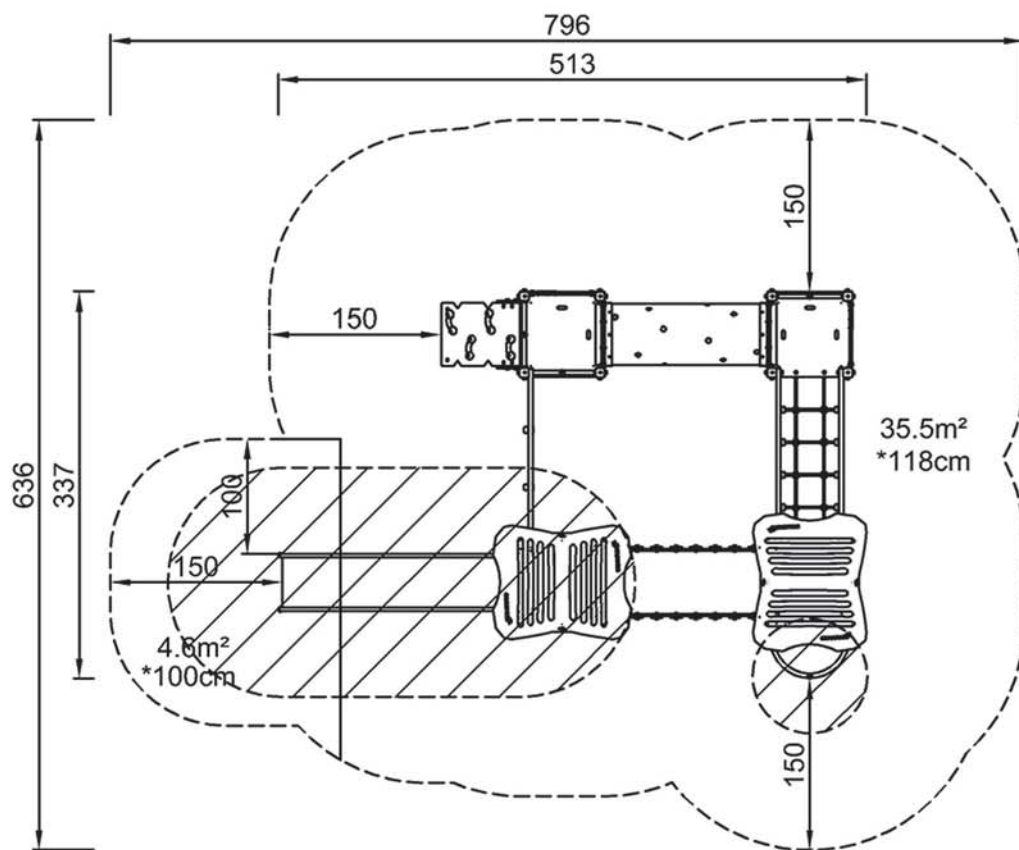
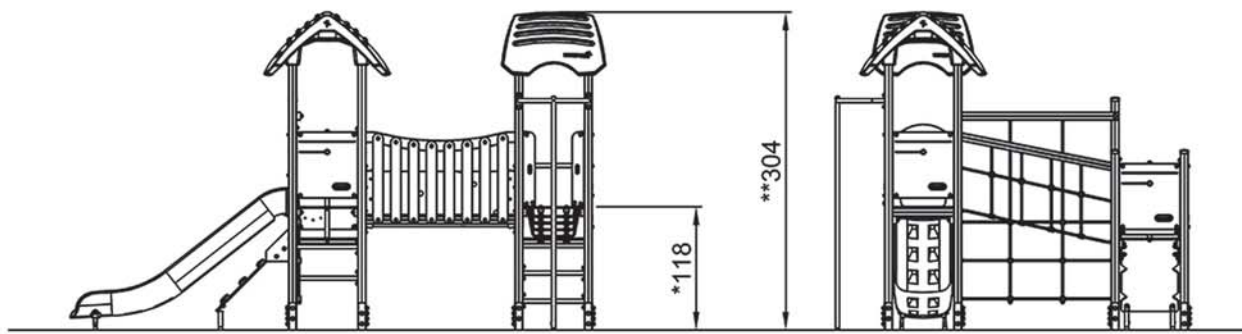

CASTELLO CON SCIVOLO

ESEMPIO

(da scheda tecnica Kompan)